

PRIMEANGLE™

S L O T T E D A N G L E S Y S T E M

BY UNISTRUT®

PRIMEANGLE™

SLOTTED ANGLE SYSTEM

A complete support system that's versatile, economical, and easy to use.

- No drilling, welding or special tools necessary
- Fast, efficient bolt-together construction
- Easy to change and adjust
- Cost-saving, reusable materials

With its standard 10' and 12' lengths, three strengths and two finishes, this Slotted Angle System fills a wide range of support needs, and requires only a 9/16" wrench for assembly. Available in pre-galvanized and acrylic green finishes.

Standard 10-piece bundles include 75 sets of serrated nuts and 3/8"-16 x 3/4" hex-head bolts.

3 VERSATILE ANGLES

PA-158

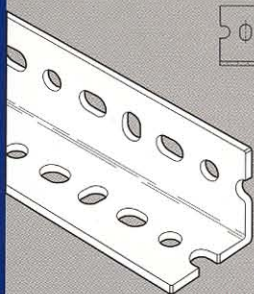
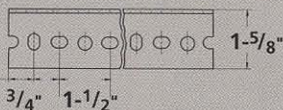

PA-158 Light-Duty (1-5/8" x 1-5/8" x 14 Ga.)

For those jobs where extra strength is not necessary. Ideal for light-duty shelving or racking.

PA-238

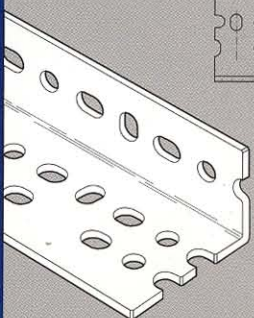
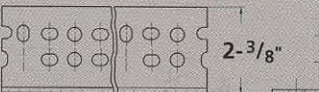
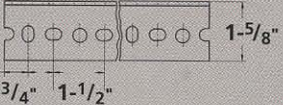

PA-238 Medium-Duty (1-5/8" x 2-3/8" x 14 Ga.)

Perfect for the majority of framing needs, including shelving, racking, and electrical or mechanical support jobs.

PA-318

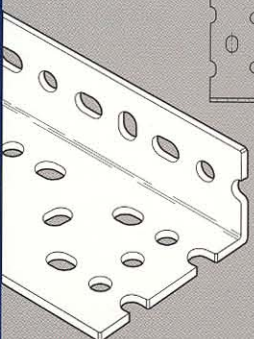
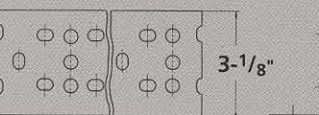
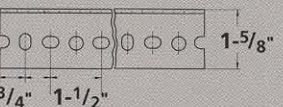

PA-318 Heavy-Duty (1-5/8" x 3-1/8" x 12 Ga.)

Suitable for balconies, ramps, large racks and shelving systems, as well as other structures with substantial load requirements.

5 SIMPLE ACCESSORIES

Gusset Plate

PA-1GP
(2-5/8" x 2-5/8" x 14 Ga.)
25 per package

Three-hole corner plate reinforces right angle connections when additional strength is required.

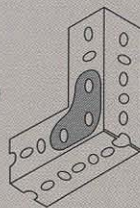

Casters

PA-1RC (Rigid) and PA-1SC (Swivel)
Two per package

Rigid and swivel designs for mobile equipment, with 3-1/2" diameter hard rubber wheels. Casters are 4-3/4" high, with mounting plate holes on 3" centers to match angle hole pattern. Each caster is load-rated at 225 lbs.



PA-15C Swivel
PA-1RC Rigid

Extra Serrated Nuts and Bolts

PA-1SNB
(3/8"-16 x 3/4")
75 sets per package



Portable Cutter PA-1HDC

The Portable Cutter cuts all three angle sizes with a single stroke. Cuts are clean, accurate and burr-free.

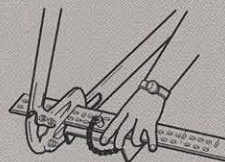

Slotted Strap

PA-1RP
(1-5/8" x 14 ga.)

Used to reinforce slotted angle sections. Hole pattern exactly matches hole pattern in slotted angles. Available in 10' and 12' lengths. Pre-galvanized finish.

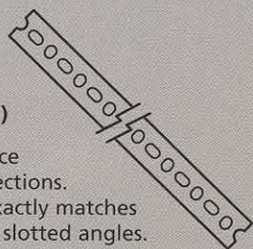

B *BEAM SELECTIONS (see corresponding letters in tables at right for load data)*

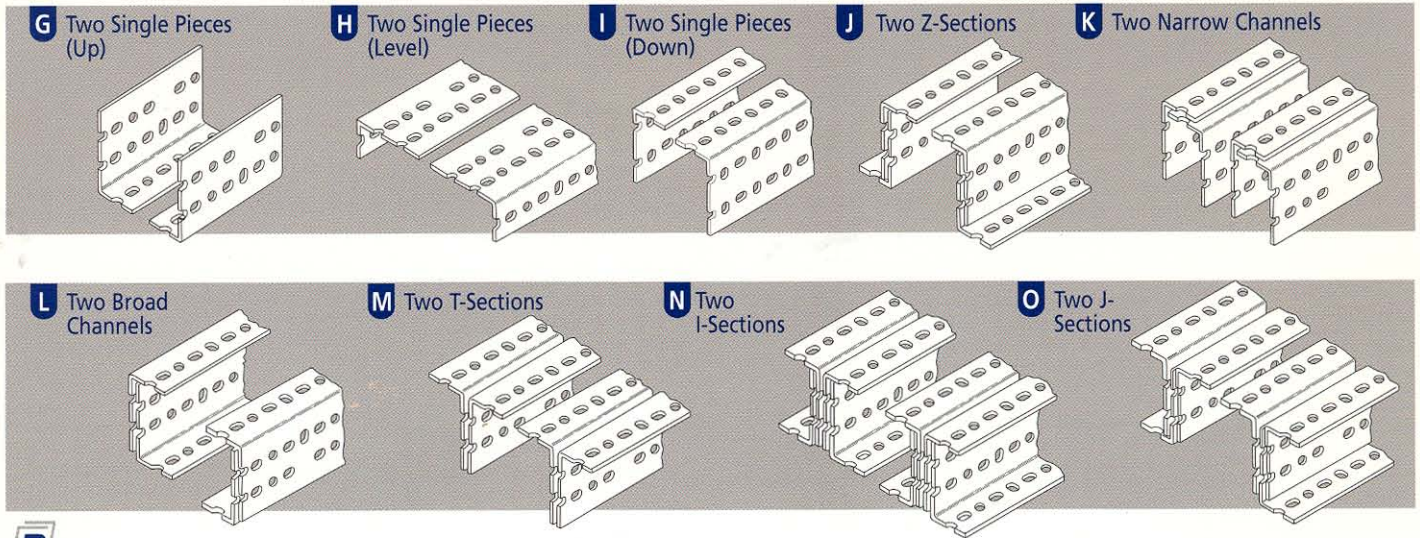

B *BEAM SELECTIONS WITH STIFFENERS (see corresponding letters in tables at right for load data)*

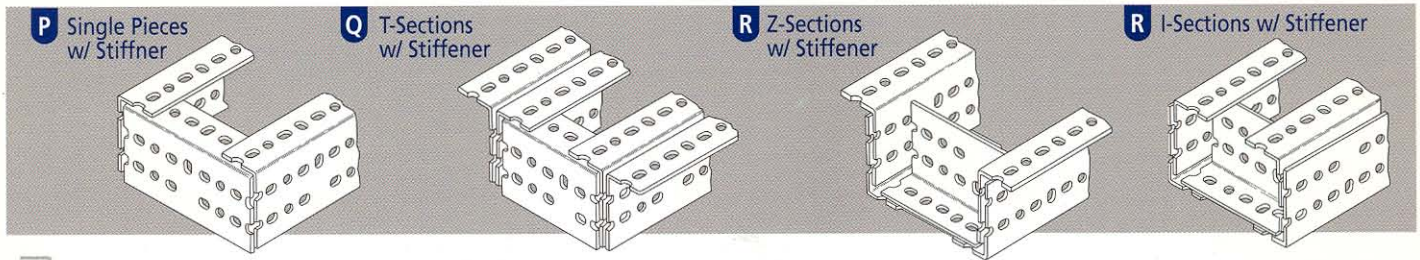

B *BEAM LOAD CALCULATIONS*

First, make a sketch of the shelves, rack, worktable or other structure needed. Next determine the slotted angle sections required by using the following procedure: (Examples assume use of PA-238 1-5/8" x 2-3/8" material.)

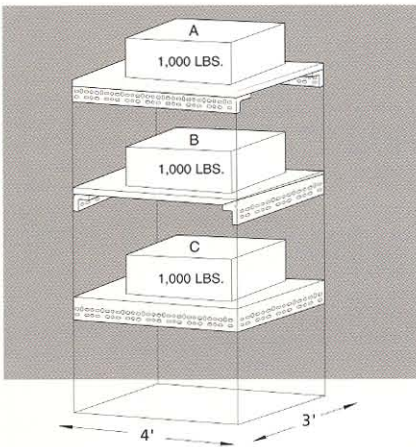

LOAD A is supported by two 48" sections. Check Table 2 under the 48" column heading to find the load that will meet your 1,000 lb. requirement. (In this case 1,110 lbs.) Next, read left to find the letter that designates the proper section or combination to use for the two beams (in this case, "J").

LOAD B is supported by two 36" sections. Check Table 2 under the 36" column heading to find the load that will meet your 1,000 lb. requirement. (In this case, 1,100 lbs.) Next, read left to find the letter that designates the proper section or combination to use for the two beams (in this case, "J").

LOAD C is supported by all four beam sections. The load is distributed uniformly on two 3-foot and two 4-foot beams, which total 14-feet of supporting beam length. Dividing the 1,000 lb. load by 14-feet equals 72 lbs. per foot. Using the two longest (weakest) lengths, calculate the total weight as follows:

$$2 \text{ (beams)} \times 4 \text{ ft. (length)} \times 72 \text{ lbs./ft.} = 576 \text{ lbs. total weight}$$

From the same table, the 48" angle section indicated on line I will support 830 lbs. and is adequate for this requirement. The 3-foot beams will support the load because they are shorter and stronger.

T *TRANSVERSE STIFFENERS*

When supporting concentrated loads, the capacity of a pair of slotted-angle beams

can be increased by the addition of transverse stiffeners. These should be placed immediately under the load bearing point. The slotted-angle segment used as the stiffener is bolted into place using a metal connector at each junction.

Beams that are 6' long or less require only one stiffener in the center of the span. Seven-foot beams need two stiffeners placed 2' from each end. Eight-foot beams require two stiffeners 2' 6" from the ends. For beams with a nine-foot span, it is necessary to have three stiffeners at 2' 3" intervals. Ten-foot beams need three stiffeners with 2' 6" spacings.

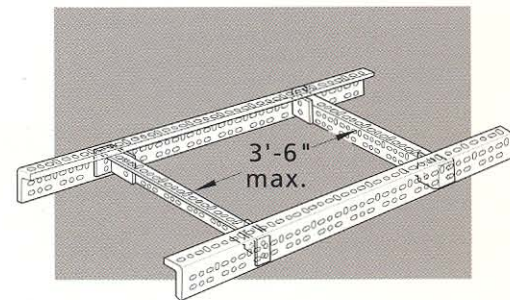

For maximum effectiveness, transverse stiffeners should never be spaced more than 3' 6" apart.

Note: All loads based on actual physical testing. Documentation available on request.

PA-158 1-5/8" x 1-5/8" x 14 GA.

BEAM SPAN (TABLE 1)

	24"(609 mm)		36"(914 mm)		48"(1219 mm)		60"(1524 mm)		72"(1829 mm)		84"(2133 mm)		96"(2438 mm)		108"(2743 mm)		120"(3048 mm)	
	LBS.	N	LBS.	N	LBS.	N	LBS.	N	LBS.	N	LBS.	N	LBS.	N	LBS.	N	LBS.	N
G	550	2450	370	1630	280	1220	220	980	180	820	•	•	•	•	•	•	•	•
H	830	3710	560	2470	420	1850	330	1480	280	1240	240	1060	210	930	•	•	•	•
I	830	3710	560	2470	420	1850	330	1480	280	1240	240	1060	210	930	•	•	•	•
P	920	4090	610	2730	460	2050	370	1640	310	1360	260	1170	230	1020	•	•	•	•
L	1600	7120	1070	4740	800	3560	640	2850	530	2370	460	2030	400	1780	360	1580	320	1420
R	1700	7560	1130	5040	850	3780	680	3020	570	2520	490	2160	430	1890	380	1680	340	1510
M	1840	8180	1230	5460	920	4090	740	3270	610	2730	530	2340	460	2050	410	1820	370	1640

Based on simple beam condition with uniform loads on parallel beams. To determine concentrated load capacity at mid-span, multiply uniform load by 0.5.

PA-238 1-5/8" x 2-3/8" x 14 GA.

BEAM SPAN (TABLE 2)

	24"(609 mm)		36"(914 mm)		48"(1219 mm)		60"(1524 mm)		72"(1829 mm)		84"(2133 mm)		96"(2438 mm)		108"(2743 mm)		120"(3048 mm)	
	LBS.	N	LBS.	N	LBS.	N	LBS.	N	LBS.	N	LBS.	N	LBS.	N	LBS.	N	LBS.	N
G	700	3100	460	2070	350	1550	280	1240	230	1030	•	•	•	•	•	•	•	•
H	1020	4540	680	3020	510	2270	410	1810	340	1510	290	1300	260	1130	•	•	•	•
I	1660	7370	1100	4910	830	3680	660	2950	550	2460	470	2110	410	1840	•	•	•	•
P	1740	7750	1160	5170	870	3880	700	3100	580	2580	500	2220	440	1940	•	•	•	•
J	2220	9860	1480	6580	1110	4930	890	3950	740	3290	630	2820	550	2470	490	2190	440	1970
L	3170	14090	2110	9390	1580	7050	1270	5640	1060	4700	910	4030	790	3520	700	3130	630	2820
R	3230	14370	2150	9580	1620	7190	1290	5750	1080	4790	920	4110	810	3590	720	3190	650	2870
M	3490	15510	2320	10340	1740	7750	1390	6200	1160	5170	1000	4430	870	3880	770	3450	700	3100
K	3590	15980	2390	10650	1800	7990	1440	6390	1200	5330	1030	4570	900	3990	800	3550	720	3200
Q	3630	16130	2420	10750	1810	8060	1450	6450	1210	5380	1040	4610	910	4030	810	3580	730	3230
O	6060	26960	4040	17970	3030	13480	2420	10780	2020	8990	1730	7700	1520	6740	1350	5990	1210	5390
N	7560	33630	5040	22420	3780	16810	3020	13450	2520	11210	2160	9610	1890	8410	1680	7470	1510	6730

Based on simple beam condition with uniform loads on parallel beams. To determine concentrated load capacity at mid-span, multiply uniform load by 0.5.

PA-318 1-5/8" x 3-1/8" x 12 GA.

BEAM SPAN (TABLE 3)

	24"(609 mm)		36"(914 mm)		48"(1219 mm)		60"(1524 mm)		72"(1829 mm)		84"(2133 mm)		96"(2438 mm)		108"(2743 mm)		120"(3048 mm)	
	LBS.	N	LBS.	N	LBS.	N	LBS.	N	LBS.	N	LBS.	N	LBS.	N	LBS.	N	LBS.	N
G	1790	7980	1200	5320	900	3990	720	3190	600	2660	•	•	•	•	•	•	•	•
H	1610	7170	1070	4780	810	3590	640	2870	540	2390	460	2050	400	1790	•	•	•	•
I	4300	19130	2870	12750	2150	9560	1720	7650	1430	6380	1230	5460	1080	4780	•	•	•	•
P	4960	22060	3310	14710	2480	11030	1980	8830	1650	7350	1420	6300	1240	5520	1100	4900	990	4410
J	6520	29020	4350	19350	3260	14510	2610	11610	2170	9670	1860	8290	1630	7260	1450	6450	1300	5800
L	7910	35180	5270	23450	3950	17590	3160	14070	2640	11730	2260	10050	1980	8790	1760	7820	1580	7040
R	8070	35880	5380	23920	4030	17940	3230	14350	2690	11960	2300	10250	2020	8970	1790	7970	1610	7180
M	9920	44130	6610	29420	4960	22060	3970	17650	3310	14710	2830	12610	2480	11030	2200	9810	1980	8830
K	9990	44430	6660	29620	4990	22210	4000	17770	3330	14810	2850	12690	2500	11110	2220	9870	2000	8890
Q	10170	45230	6780	30150	5080	22610	4070	18090	3390	15080	2910	12920	2540	11310	2260	10050	2030	9050
O	14600	64940	9730	43300	7300	32470	5840	25980	4870	21650	4170	18560	3650	16240	3240	14430	2920	12990
N	16120	71710	10750	47800	8060	35850	6450	28680	5370	23900	4610	20490	4030	17930	3580	15930	3220	14340

Based on simple beam condition with uniform loads on parallel beams. To determine concentrated load capacity at mid-span, multiply uniform load by 0.5.

C COLUMN SECTIONS (see corresponding letters in tables below for load data)

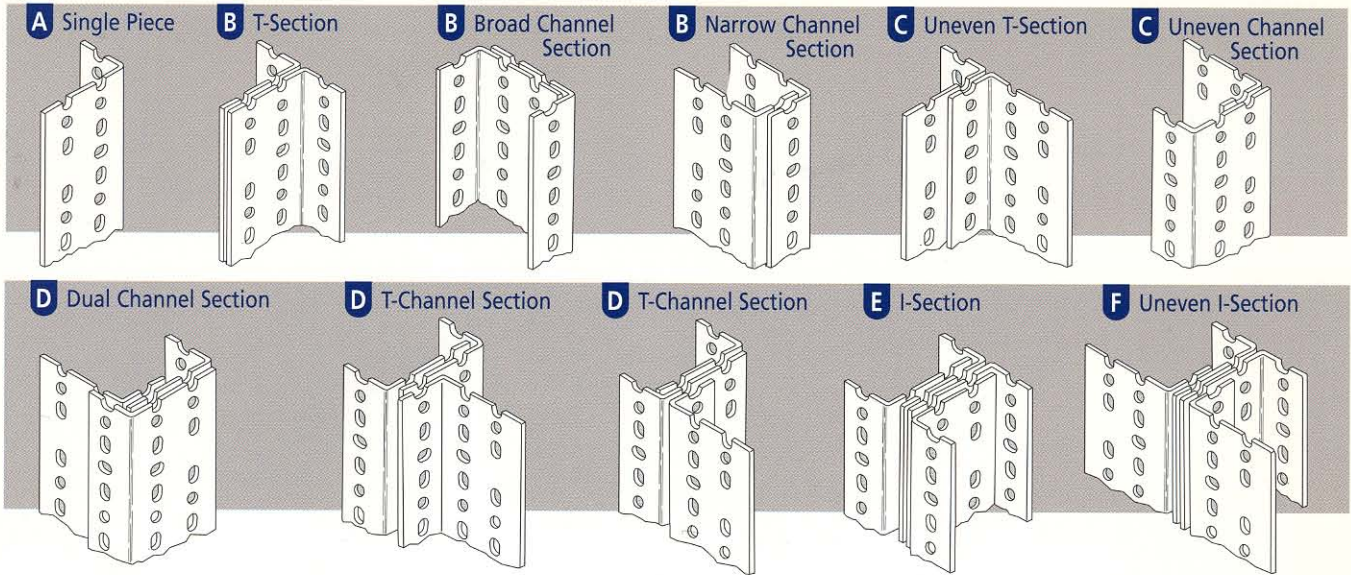

C COLUMN LOAD CALCULATIONS

Column Sections are calculated in the following manner:

(Example assumes use of PA-238 1-5/8" x 2-3/8" material.)

Since all load areas are supported equally by the 4-columns, the calculations are based on a single-column section.

The load for column section MN is one-fourth of Load X, or 250 pounds. Column section NP supports one-fourth of Load Y (250 pounds) plus the load supported by MN, or a total of 500 pounds. Section PQ carries one-fourth of Load Z (250 pounds) plus the 500 pound load on section NP, or a total of 750 pounds.

Column loads are based on free and unbraced column lengths. And because Column sections MN, NP and PQ are each 3 feet long, the load requirement is for a 36" section that will bear 750 pounds safely. A reference to Table 2 indicates that all sections designated "A" will support 2,280 lbs. and meet the necessary requirements.

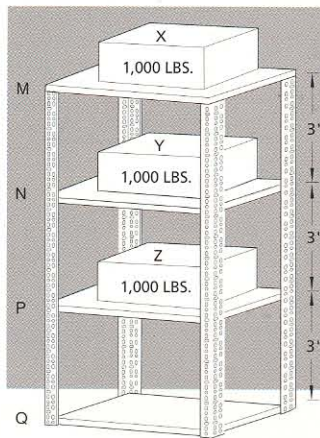

NOTE: To simplify assembly, we recommend using the same size material as for the horizontal members. This would be found in Table 2 to match the 14 gauge 1-5/8" x 2-3/8" material selected for the beams of this structure.

C COLUMN LOADS

PA-158 1-5/8" x 1-5/8" x 14 GA.

	COLUMN HEIGHT (TABLE 1)							
	36"(914 mm)		48"(1219mm)		60"(1524 mm)		72"(1829 mm)	
	LBS.	N	LBS.	N	LBS.	N	LBS.	N
A	1450	6450	1150	5115	950	4226	750	3336
B	3850	17125	3500	15569	3000	13344	2500	11120

Column Loads are concentric without intermediate lateral support.

PA-238 1-5/8" x 2-3/8" x 14 GA.

	COLUMN HEIGHT (TABLE 2)															
	36"(914 mm)		48"(1219mm)		60"(1524 mm)		72"(1829 mm)		84"(2133 mm)		96"(2438 mm)		108"(2743mm)		120"(3048 mm)	
	LBS.	N	LBS.	N	LBS.	N	LBS.	N	LBS.	N	LBS.	N	LBS.	N	LBS.	N
A	2280	10142	1970	8763	1520	6761	1070	4759	660	2963	•	•	•	•	•	•
B	4760	21173	4490	19972	3995	17770	3140	13967	2340	10409	1750	7784	•	•	•	•
C	4940	21974	4680	20817	4310	19172	3870	17214	3665	16303	2700	12010	2060	9163	1610	7161
D	7270	32338	6920	30781	6370	28335	5840	25977	4930	21930	3850	17125	2870	12766	2060	9163
E	9520	42347	8970	39900	7990	35541	6280	27935	4660	20729	3500	15569	•	•	•	•
F	9865	43881	9330	41502	8620	38343	7715	34318	6740	29981	5365	23865	4115	18304	3210	14279

Column Loads are concentric without intermediate lateral support.

PA-318 1-5/8" x 3-1/8" x 12 GA.

	COLUMN HEIGHT (TABLE 3)															
	36"(914 mm)		48"(1219mm)		60"(1524 mm)		72"(1829 mm)		84"(2133 mm)		96"(2438 mm)		108"(2743mm)		120"(3048 mm)	
	LBS.	N	LBS.	N	LBS.	N	LBS.	N	LBS.	N	LBS.	N	LBS.	N	LBS.	N
A	3470	15435	2870	12766	1970	8763	1280	5694	•	•	•	•	•	•	•	•
B	7970	35452	7360	32739	6570	29225	5270	23442	3670	16325	2580	11476	•	•	•	•
C	8770	39011	8580	38166	8180	36386	7690	34207	6970	31004	6260	27846	5460	24287	4460	19839
D	12560	55869	11970	53245	11360	50532	10480	46617	9470	42124	8370	37231	6880	30604	5370	23887
E	15940	70904	14750	65611	13160	58538	10560	46973	7370	32783	5170	22997	•	•	•	•
F	17550	78066	17150	76287	16360	72773	15360	68324	13970	62141	12570	55914	10970	48797	8960	39856

Column Loads are concentric without intermediate lateral support.

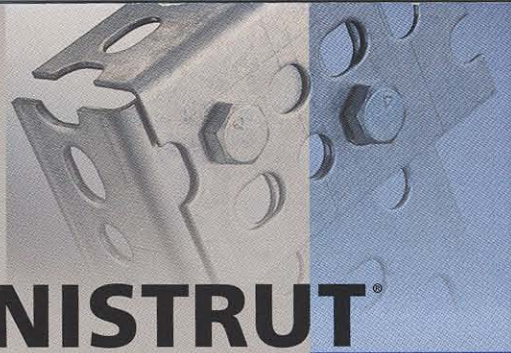

UNISTRUT[®]

PrimeAngle[™]

SLOTTED ANGLE SYSTEM

SPECIFICATIONS

- Engineered for ease of assembly

The slot and hole pattern is repeated every 3", for maximum convenience and performance.

- Two durable, long-lasting finishes.

- Pre-galvanized

System elements are coated with zinc by hot-dip process prior to roll-forming or press operations. The zinc coating weight is G90 conforming to ASTM Specification A653.

- Perma-Green[®] II

Angle and parts are carefully cleaned and phosphated. Immediately after phosphating, a uniform coat of a highly effective rust-inhibiting acrylic enamel paint is applied by electro-deposition and thoroughly cured. Color is per Federal Standard 595a color number 14109 (dark limit V-). The resulting finish will withstand 400 hours of salt spray when tested in accordance with ASTM B-117.

- Available in Two Lengths

Standard lengths are 10' (3.05 m) and 12' (3.66 m). Slotted angle is shipped in ten-piece bundles complete with 75 pieces of 3/8" -16 x 3/4" hex head bolts, and 3/8" nuts.

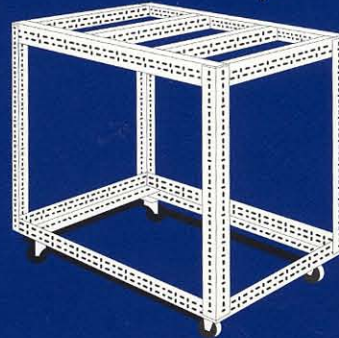
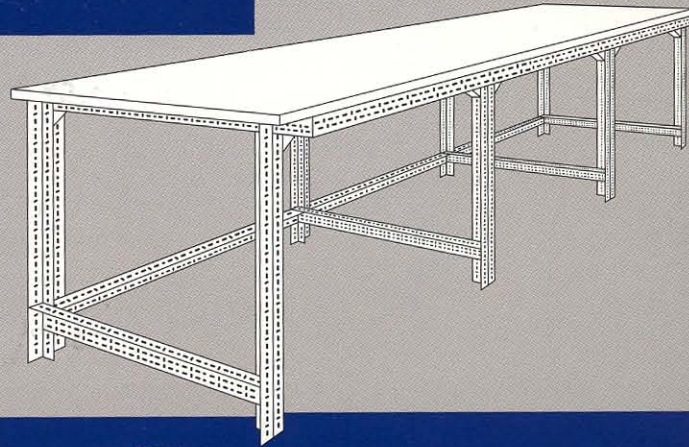
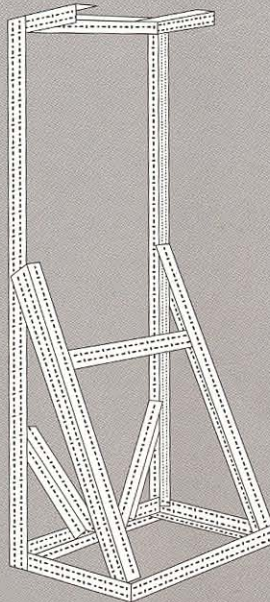

UNISTRUT[®]

Unistrut Diversified Products
35660 Clinton Street
Wayne, MI 48184
1-800-521-7730