

GENERAL NOTES

1. THIS UNISTRUT SUPPORT SYSTEM IS DESIGNED TO SUPPORT A MAXIMUM 1,500 FT/LBS. MOMENT LOAD.
2. AREA DIRECTLY ABOVE THE SUPPORT TO BE FREE AND CLEAR OF ALL OBSTRUCTIONS.
3. EXISTING STRUCTURE TO BE CHECKED BY OTHERS.
4. ALL CHANNEL & FITTINGS TO HAVE STANDARD UNISTRUT "PERMA-GREEN" FINISH AND ALL HARDWARE TO BE ELECTRO-GALVANIZED.

UPPER STRUCTURE IS TYPICAL PLEASE CONTACT YOUR LOCAL UNISTRUT CONSTRUCTION OFFICE FOR SPECIFIC APPLICATION DESIGN.

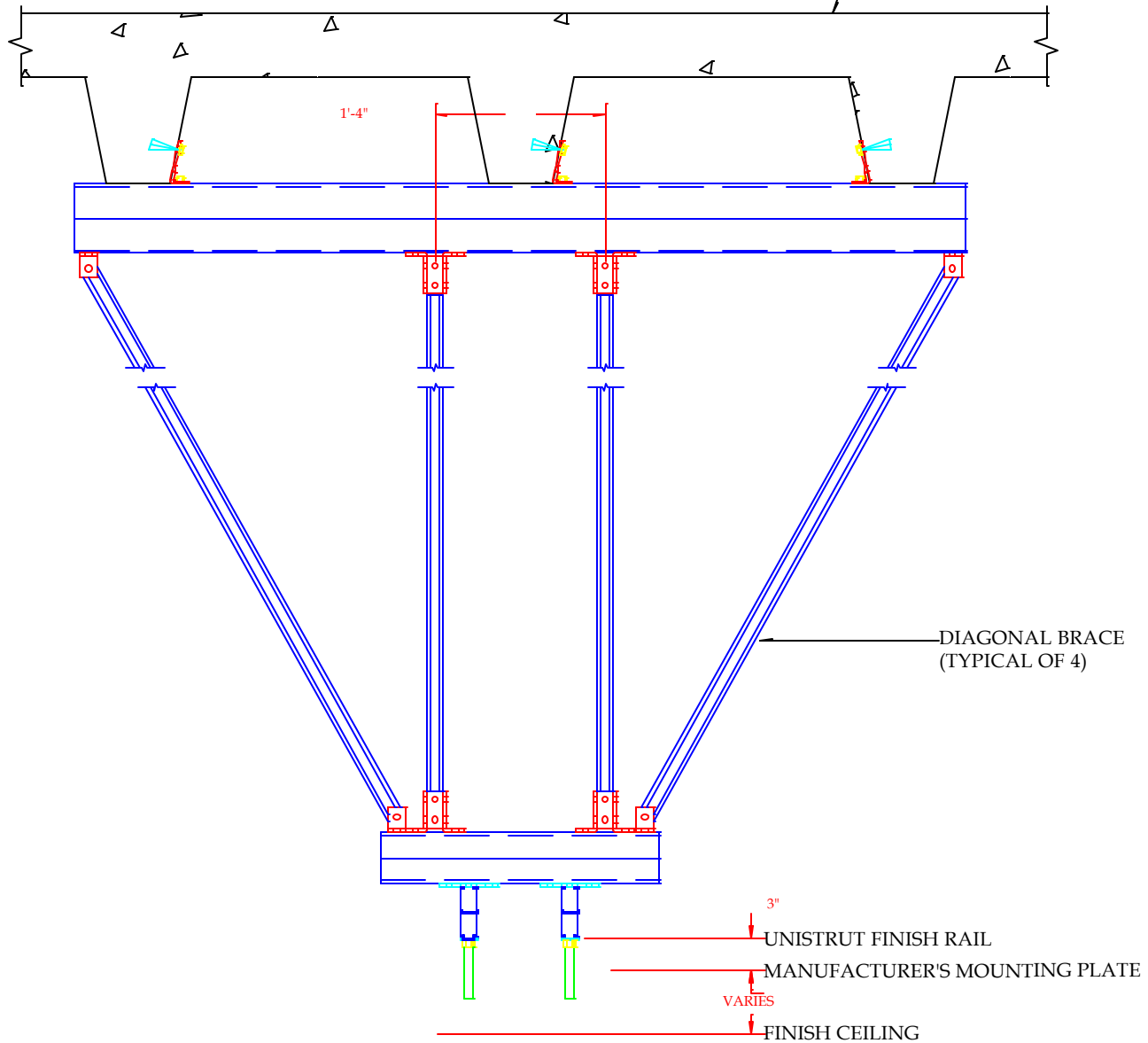

SECTION VIEW : UNISTRUT SUPPORT

SCALE : 3/4" = 1'-0"

UNISTRUT CORPORATION

DESIGN & INSTALLATION
CONSTRUCTION DIVISION
PHONE:1-800-468-9510

UNISTRUT MEDICAL
LIGHT SUPPORT

BY SB

DATE 11/24/03

LT-15-CB

SHEET
1 OF 1

GENERAL NOTES

- 1. THIS UNISTRUT SUPPORT SYSTEM IS DESIGNED TO SUPPORT A MAXIMUM 1,500 FT/LBS. MOMENT LOAD.
- 2. AREA DIRECTLY ABOVE THE SUPPORT TO BE FREE AND CLEAR OF ALL OBSTRUCTIONS.
- 3. EXISTING STRUCTURE TO BE CHECKED BY OTHERS.
- 4. ALL CHANNEL & FITTINGS TO HAVE STANDARD UNISTRUT "PERMA-GREEN" FINISH AND ALL HARDWARE TO BE ELECTRO-GALVANIZED.

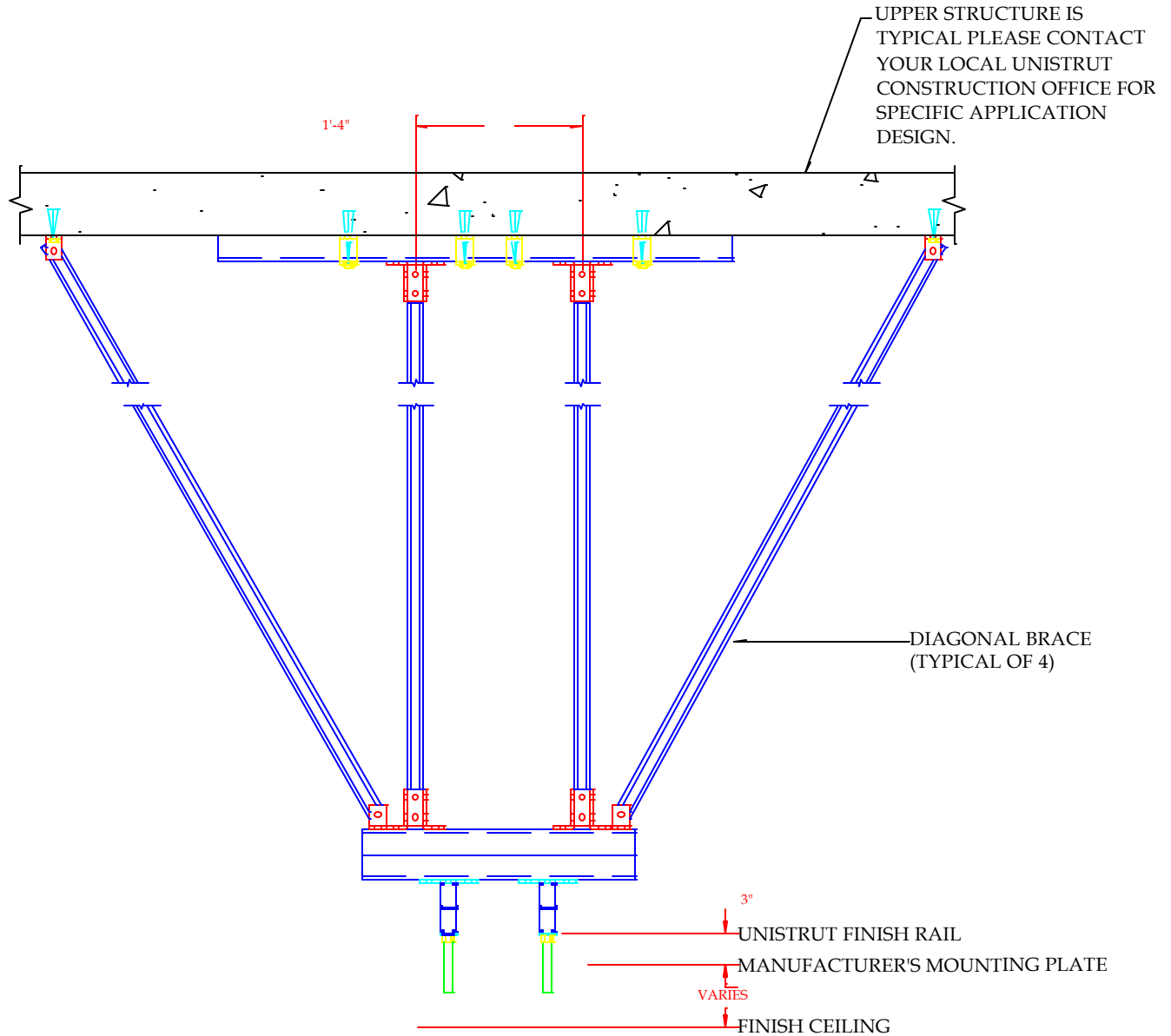

SECTION VIEW : UNISTRUT SUPPORT

SCALE : 3/4" = 1'-0"

UNISTRUT CORPORATION

DESIGN & INSTALLATION
CONSTRUCTION DIVISION
PHONE:1-800-468-9510

UNISTRUT MEDICAL
LIGHT SUPPORT

BY SB

DATE 11/24/03

LT-15-CS

SHEET
1 OF 1

GENERAL NOTES

1. THIS UNISTRUT SUPPORT SYSTEM IS DESIGNED TO SUPPORT A MAXIMUM 1,500 FT/LBS. MOMENT LOAD.
2. AREA DIRECTLY ABOVE THE SUPPORT TO BE FREE AND CLEAR OF ALL OBSTRUCTIONS.
3. EXISTING STRUCTURE TO BE CHECKED BY OTHERS.
4. ALL CHANNEL & FITTINGS TO HAVE STANDARD UNISTRUT "PERMA-GREEN" FINISH AND ALL HARDWARE TO BE ELECTRO-GALVANIZED.

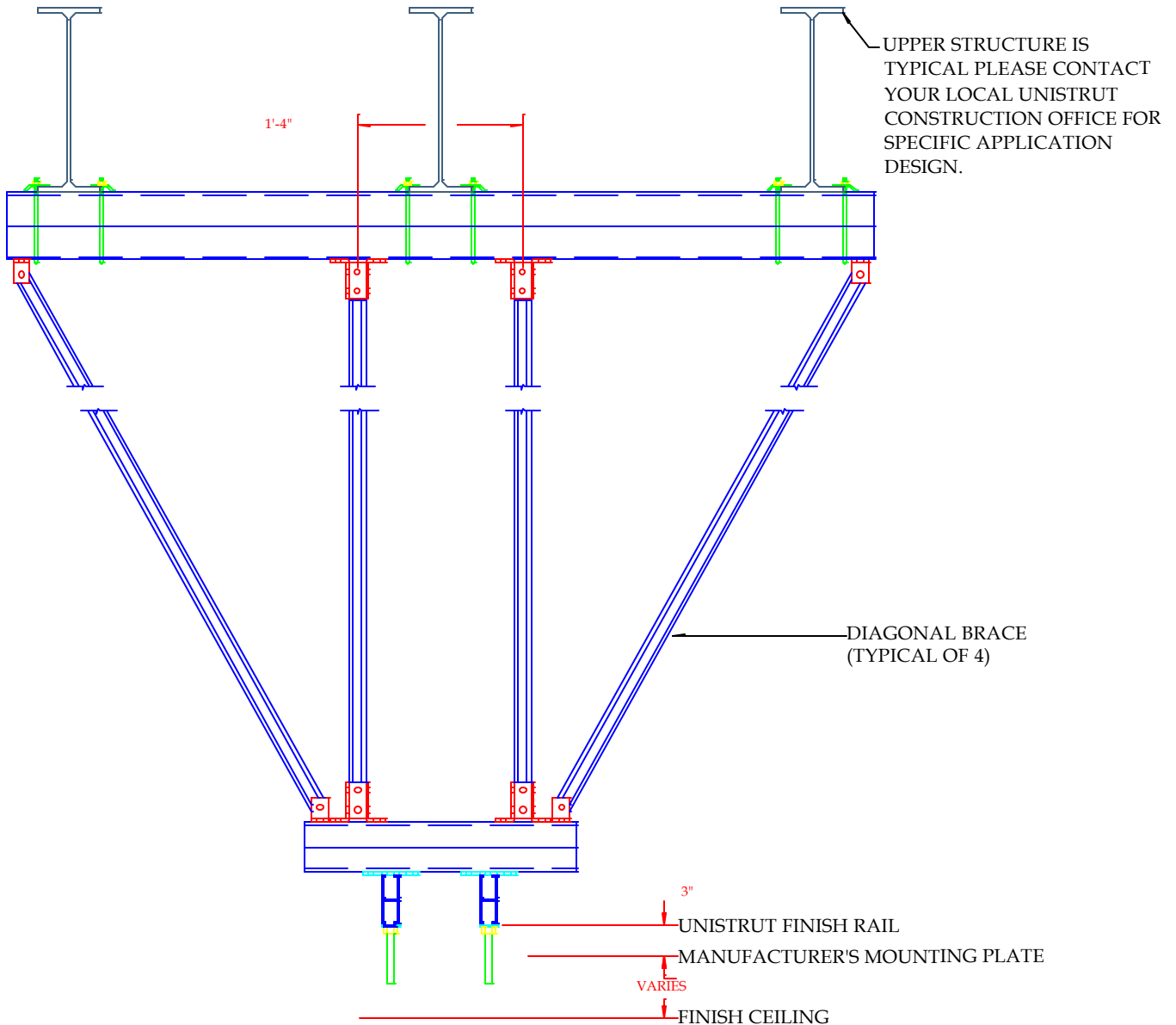

SECTION VIEW : UNISTRUT SUPPORT

SCALE : 3/4" = 1'-0"

UNISTRUT CORPORATION

DESIGN & INSTALLATION
CONSTRUCTION DIVISION
PHONE:1-800-468-9510

UNISTRUT MEDICAL
LIGHT SUPPORT

BY SB

DATE 11/24/03

LT-15-SB

SHEET
1 OF 1

GENERAL NOTES

1. THIS UNISTRUT SUPPORT SYSTEM IS DESIGNED TO SUPPORT A MAXIMUM 1,500 FT/LBS. MOMENT LOAD.
2. AREA DIRECTLY ABOVE THE SUPPORT TO BE FREE AND CLEAR OF ALL OBSTRUCTIONS.
3. EXISTING STRUCTURE TO BE CHECKED BY OTHERS.
4. ALL CHANNEL & FITTINGS TO HAVE STANDARD UNISTRUT "PERMA-GREEN" FINISH AND ALL HARDWARE TO BE ELECTRO-GALVANIZED.

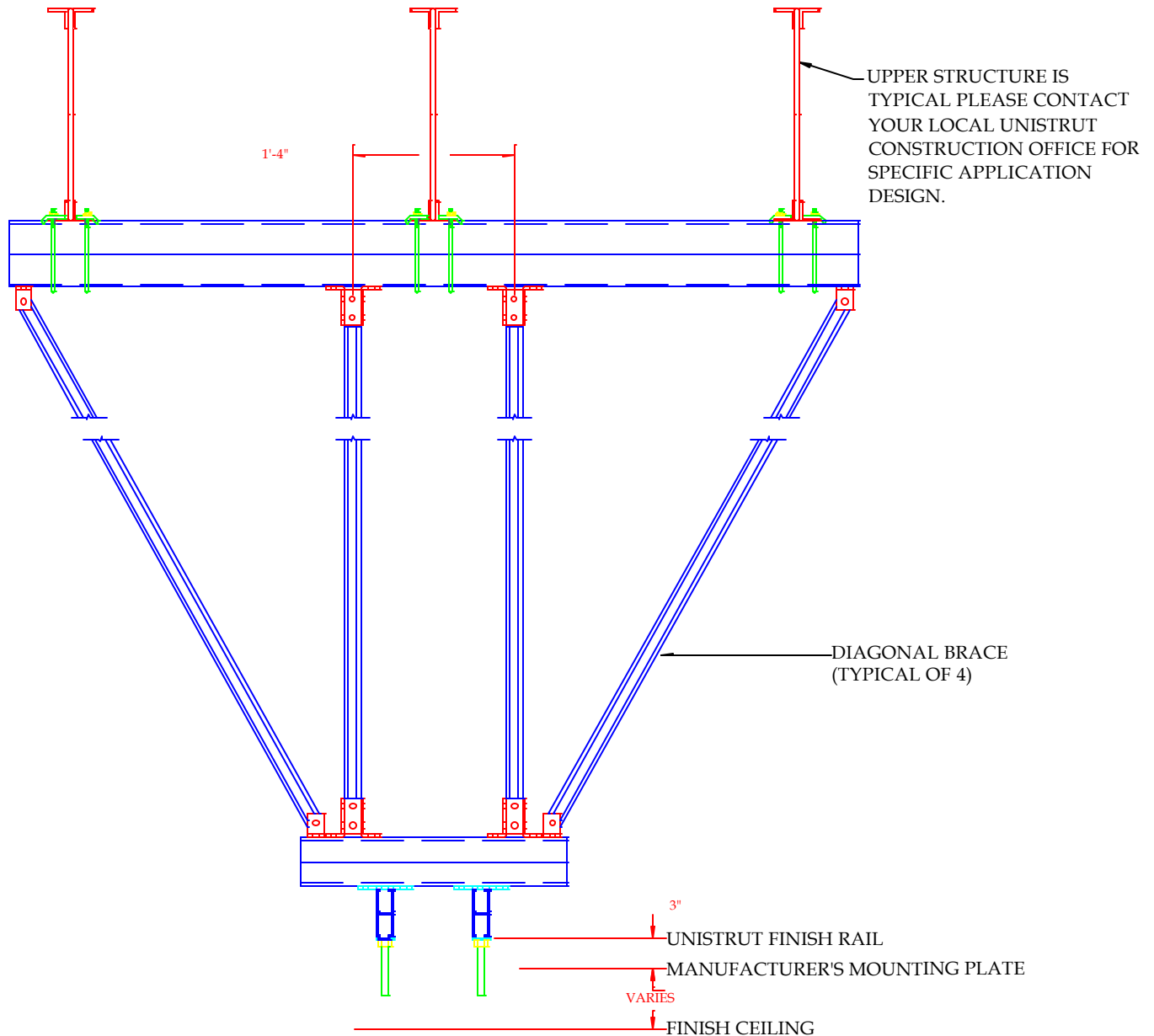

SECTION VIEW : UNISTRUT SUPPORT

SCALE : 3/4" = 1'-0"

UNISTRUT CORPORATION

DESIGN & INSTALLATION
CONSTRUCTION DIVISION
PHONE:1-800-468-9510

UNISTRUT MEDICAL
LIGHT SUPPORT

BY SB

DATE 11/24/03

LT-15-SJ

SHEET
1 OF 1

MEDICAL EQUIPMENT SUPPORTS
SECTION 05600

1. GENERAL

A. SCOPE

1. Contractor shall provide and install a medical support system(s) as indicated on the reflected ceiling plans, in rooms _____ located at _____.

Rail shall be on centers as required by equipment manufacturer and allow continuous attachment along any point on the rail. System shall be true, plumb and level to the tolerances indicated, with no more than 1/720th of the span maximum deflection in either plane, when maximum loading conditions are applied due to equipment operation.

2. Work of others sections
 - a) Ceiling
 - b) Painting
 - c) Electrical
 - d) _____

B. QUALITY ASSURANCE

1. Material and installation shall be provided by a qualified vendor, with at least ten (10) years experience in the manufacture and installation of metal framing medical equipment supports. Vendor shall demonstrate experience of projects of similar scope and size, and shall maintain a continuing quality assurance program for both its material and installation crews.
2. Vendor shall provide the single source responsibility for materials and workmanship, and shall provide a warranty period of one (1) year from date of acceptance by architect/owner.
3. Acceptable Vendors: Unistrut Construction or approved equivalent contractor.

C. SUBMITTAL

1. Shop Drawings: Successful vendor shall submit shop drawings showing the complete system, including plans, sections and details of the system. Plans shall show all manufactured parts, by catalog numbers, all fabricated parts, and all fasteners and hardware.
2. Manufacturer's Brochure: Brochure shall show materials, strengths, finishes and sizes. Sufficient engineering information shall be provided to permit stress calculations. Materials listed should conform to the appropriate specifications from ASTM, AISI, AISC, and/or AWS.
3. Calculations (optional): The medical support system shall lend itself to a rational structural analysis with section properties of framing members demonstrated by calculations. Structural calculations and drawings shall be furnished with a stamp by a licensed engineer complying with all applicable codes and regulatory requirements.

II. MATERIAL AND DESIGN

A. MATERIAL

1. Materials used shall conform to the following ASTM specifications: ASTM 653SQ33, ASTM A570 Grade 33, ASTM A575, ASTM 675 Grade 50, SAE J429 Grade 2.
2. All materials shall be protected from corrosion with a factory applied finish.
3. All materials shall be stamped and identifiable by manufacturer and part number (where appropriate). Materials that appear damaged, distressed, unidentifiable or rusted shall not be used and will not be accepted.

B. DESIGN

1. Support Structure: The support members at the ceiling plane shall be located as indicated on the drawings. They shall be manufactured by "Unistrut Corporation" or approved equal. The spacing shall allow installation of standard modular 24" ceiling fixtures and equipment. It shall be possible to attach the medical equipment at any point on the support system.
2. Ceiling Anchorage: Whenever possible, attachment to ceiling structure above shall be done by means of imbedded concrete inserts, through bolts, expansion anchors or by direct attachment to the structural framing of the building.

3. Vertical supports: The exposed rails and the ceiling anchorage shall be connected by a series of vertical supports as indicated on the drawings. Vertical supports shall provide for both basic and micro vertical adjustment.
4. Seismic Bracing: Medical system shall be adequately braced to meet all code requirements.
5. Loading: The support structure shall be designed to support a concentrated load of _____ lbs. , at any single point along the exposed rails. The concentrated load shall be the maximum that will be encountered by positioning the equipment at the extremities of its travel (maximal load configuration).
6. Safety Factor: The system shall be designed with a minimum safety factor of 2 _ based on ultimate strength under static loading conditions.
7. Maximum deflection attributed to the support structure is not to be greater than 1/16”.

III. INSTALLATION

A. FIELD MEASUREMENTS

The contractor shall make field measurements to assure that the medical support can be installed according to plans, and without interference with structural framing, mechanical systems, plumbing or other obstructions. Any interferences shall be reported to the architect.

B. SEQUENCING

The contractor shall assure that the support system is installed in a timely and practical sequence, ahead of any extensive electrical, mechanical or HVAC work in the area, and prior to any ceiling framing or room finishes.

C. PAINTING

All exposed members shall be painted by the painting contractor with paint compatible to the support systems.

D. MODIFICATIONS

Any changes or modifications from approved shop drawings shall require approval from the architect and engineer, and shall be noted on the final drawings.

E. LIABILITY

Installing contractor shall be able to furnish coverage liability insurance with limitation of no less than one million dollars. Material, design and installations shall be furnished by a single source to minimize total liability.